

**SPECIFICATION**

A: MATERIAL:

- 1.BODY: NYLON 66
- 2.TERMINAL: Cu PLATED Sn
- 3.PIN: Cu PLATED Ni
- 4.WIRE: UL 3266, 18AWG, BLACK
- 5.WIRE: UL 3266, 18AWG, WHITE
- 6.HOOK TYPE:H11818PS-2 & APPROVAL EQUIVALENT
- 7.HOOK TYPE:H11818PS-2 & APPROVAL EQUIVALENT
- 8.COVN: NYLON 66
- 9.TUBE: TUBE-HST 0.25\*3.0 125C 600V B
- 10.TUBE: TUBE-HST 0.25\*3.0 125C 600V B

B: CHARACTERISTICS:

- 1.RATING: 15A 250V~(C-ULus)  
10A 250V~(ENEC & CCC)
- 2.INSULATION RESISTANCE:100MΩ MIN,AT 500VDC
- 3.ELECTRIC STRENGTH : 3000 VAC/1MIN,LEAKAGE CURRENT UNDER 0.5mA

C: APPROVALS: C-ULus, ENEC & CCC

D: MATERIAL USED MUST BE COMPLY WITH HQI-0010

E: CAN MEET RoHS, RoHS2.0, HF

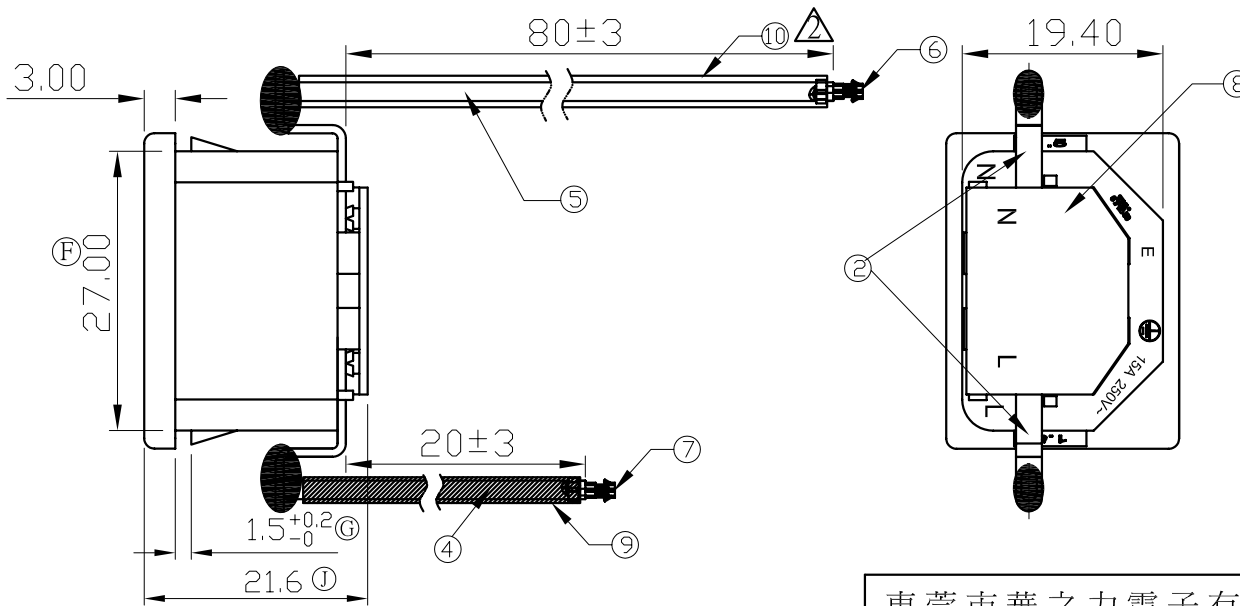
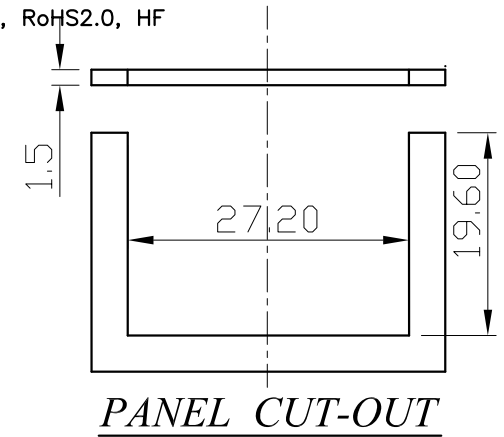

TOLERANCES UNLESS OTHERWISE 未指定容許差尺寸之公差	
BASIC DIMENSIONS TOLERANCES	
UP TO 10 (10以下)	±0.15
ABOVE 10 TO 30(10~30)	±0.3
ABOVE 30 TO 100(30~100)	±0.5
ANGULAR DIMENSIONS(角度)	±5°
DIMENSION UNIT	mm

東莞市華之力電子有限公司 DONGGUAN HCR ELECTRONICS CO., LTD.

2	2013/01/22	1. A: MATERIAL: 增加第10條	A2	KANG	RZTang	核准 APPROVED BY	AaronJin	日期 DATE	20130122	投影法 PROJECT		機型 PART NAME	INLET SOCKET
1	2013/01/09	變更料號: SK05-02010821BH-5002=>SK05-02010821BH-5001	A1	KANG	RZTang	校對 CHECKED BY	RZTang	日期 DATE	20130122	比例 SCALE	1:1	型號 PART NO	SK05
0	2012/12/21	1. 新制訂	A0	KANG	RZTang	繪圖 DRAWN BY	KANG	日期 DATE	20130122	路徑 DWG NO	E:\成品圖 \SK05\850007	料號 ITEM NO	△SK05-02010821BH-5001
NO	DATE	REVISION DESCRIPTION	REVISION	DRAWN	APPROVED								